

DIGITRON SEMICONDUCTORS

MCR220-5, MCR220-7, MCR220-9

SILICON CONTROLLED RECTIFIER

Available Non-RoHS (standard) or RoHS compliant (add PBF suffix).

Available as "HR" (high reliability) screened per MIL-PRF-19500, JANTX level. Add "HR" suffix to base part number.

MAXIMUM RATINGS

Rating	Symbol	Value	Unit
Peak repetitive forward and reverse blocking voltage⁽¹⁾ ($T_J = -40$ to $+125^\circ\text{C}$) MCR220-5 MCR220-7 MCR220-9	V_{RRM}, V_{DRM}	300 500 700	Volts
On state RMS current (all conduction angles, $T_C = 90^\circ\text{C}$)	$I_{T(RMS)}$	12	Amps
Peak non-repetitive surge current (1/2 cycle, 60Hz, sine wave, $T_J = 125^\circ\text{C}$)	I_{TSM}	100	Amps
Circuit fusing considerations ($t = 8.3\text{ms}$, $T_J = -40$ to $+125^\circ\text{C}$)	I^2t	40	A^2s
Forward peak gate power	P_{GM}	20	Watts
Forward average gate power	$P_{G(AV)}$	0.5	Watts
Forward peak gate current	I_{GM}	2	Amps
Operating junction temperature range	T_J	-40 to +125	$^\circ\text{C}$
Storage temperature range	T_{stg}	-40 to +150	$^\circ\text{C}$

Note 1: V_{DRM} and V_{RRM} for all types can be applied on a continuous basis without incurring damage. Ratings apply for zero or negative gate voltage; however, positive gate voltage shall not be applied concurrent with negative potential on the anode. Blocking voltages shall not be tested with a constant current source such that the voltage ratings of the devices are exceeded.

THERMAL CHARACTERISTICS

Characteristic	Symbol	Maximum	Unit
Thermal resistance, junction to case	$R_{\theta JC}$	2.0	$^\circ\text{C}/\text{W}$

ELECTRICAL CHARACTERISTICS ($T_C = 25^\circ\text{C}$ unless otherwise noted)

Characteristic	Symbol	Min.	Typ.	Max.	Unit
OFF CHARACTERISTICS					
Peak forward or reverse blocking current ($V_{AK} = \text{Rated } V_{DRM} \text{ or } V_{RRM}, \text{ gate open}$) $T_J = 25^\circ\text{C}$ $T_J = 125^\circ\text{C}$	$I_{DRM} \text{ or } I_{RRM}$	- -	- -	10 2.0	μA mA
ON CHARACTERISTICS					
Peak forward on-state voltage ($I_{TM} = 24\text{A peak}$)	V_{TM}	-	1.7	2.2	Volts
Gate trigger current (continuous dc) ($V_D = 12 \text{Vdc}, R_L = 100 \Omega$)	I_{GT}	-	5.0	30	mA
Gate trigger voltage (continuous dc) ($V_D = 12 \text{Vdc}, R_L = 100 \Omega$)	V_{GT}	-	0.7	1.5	Volts
Gate non-trigger voltage ($V_D = \text{Rated } V_{DRM}, R_L = 100 \Omega, T_J = 125^\circ\text{C}$)	V_{GD}	0.2	-	-	Volts
Holding current ($V_D = 12\text{Vdc}$)	I_H	-	6.0	40	mA
Turn on time ($I_{TM} = 12\text{A}, I_{GT} = 40\text{mAdc}, V_D = \text{rated } V_{DRM}$)	t_{gt}	-	1.0	2.0	μs

DIGITRON SEMICONDUCTORS

MCR220-5, MCR220-7, MCR220-9

SILICON CONTROLLED RECTIFIER

Characteristic	Symbol	Min.	Typ.	Max.	Unit
Turn-off time ($V_D = \text{rated } V_{DRM}$) ($I_{TM} = 12A, I_R = 12A$) ($I_{TM} = 12A, I_R = 12A, T_J = 125^\circ C$)	t_q	-	15 35	-	μs
DYNAMIC CHARACTERISTICS					
Critical rate of rise of off-state voltage exponential ($V_D = \text{rated } V_{DRM}, T_J = 125^\circ C$)	dv/dt	-	50	-	V/ μs

MECHANICAL CHARACTERISTICS

Case	TO-220AB
Marking	Body painted, alpha-numeric
Pin out	See below

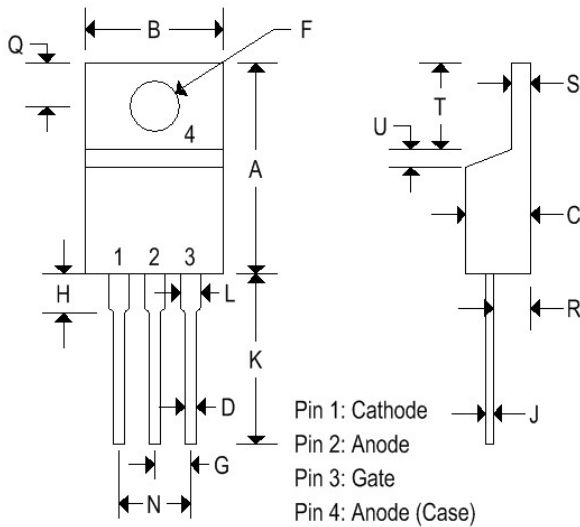

	TO-220AB			
	Inches		Millimeters	
	Min	Max	Min	Max
A	0.575	0.620	14.600	15.750
B	0.380	0.405	9.650	10.290
C	0.160	0.190	4.060	4.820
D	0.025	0.035	0.640	0.890
F	0.142	0.147	3.610	3.730
G	0.095	0.105	2.410	2.670
H	0.110	0.155	2.790	3.930
J	0.014	0.022	0.360	0.560
K	0.500	0.562	12.700	14.270
L	0.045	0.055	1.140	1.390
N	0.190	0.210	4.830	5.330
Q	0.100	0.120	2.540	3.040
R	0.080	0.110	2.040	2.790
S	0.045	0.055	1.140	1.390
T	0.235	0.255	5.970	6.480
U	-	0.050	-	1.270
V	0.045	-	1.140	-
Z	-	0.080	-	2.030

DIGITRON SEMICONDUCTORS

MCR220-5, MCR220-7, MCR220-9

SILICON CONTROLLED RECTIFIER

Voltage Current Characteristic of SCR

Symbol	Parameter
V_{DRM}	Peak Repetitive Off State Forward Voltage
I_{DRM}	Peak Forward Blocking Current
V_{RRM}	Peak Repetitive Off State Reverse Voltage
I_{RRM}	Peak Reverse Blocking Current
V_{TM}	Peak On State Voltage
I_H	Holding Current

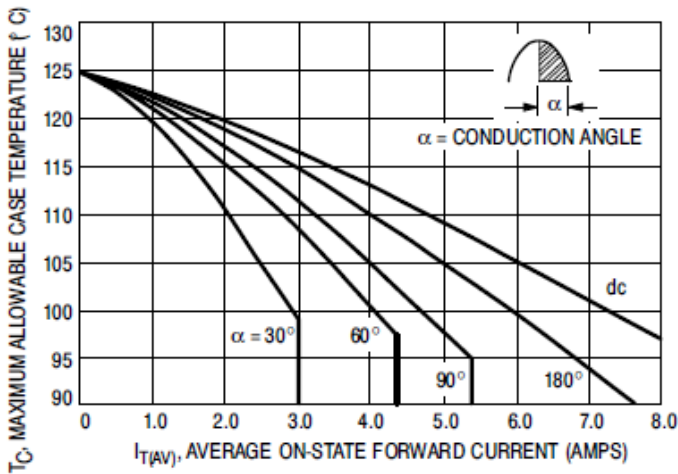
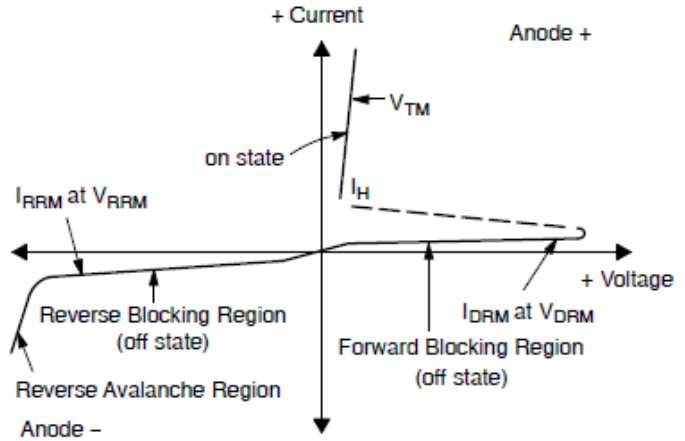

Figure 1. Current Derating

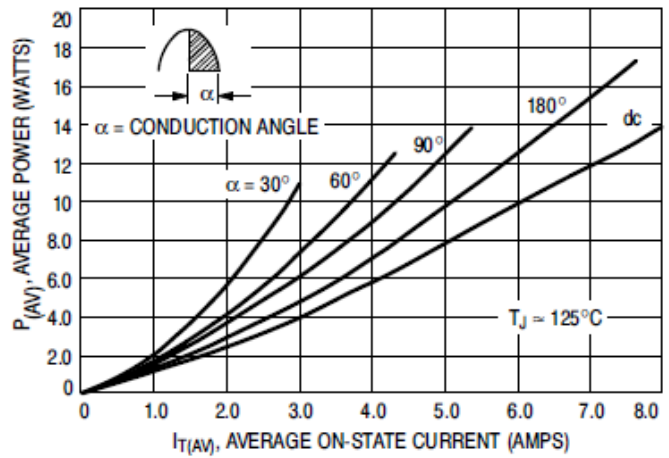

Figure 2. Maximum On-State Power Dissipation

DIGITRON SEMICONDUCTORS

MCR220-5, MCR220-7, MCR220-9

SILICON CONTROLLED RECTIFIER

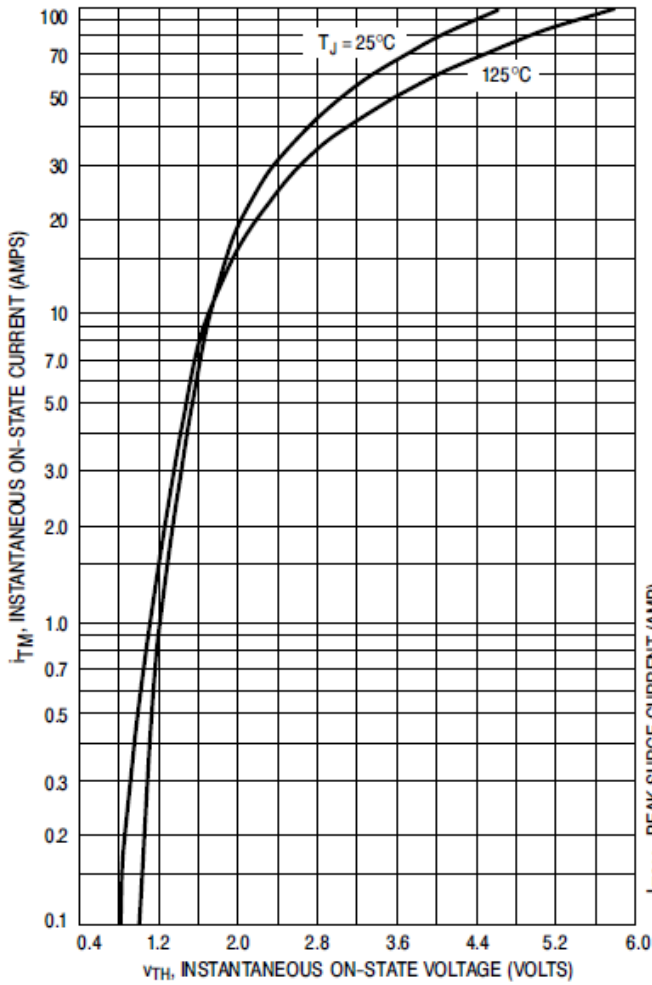

Figure 3. On-State Characteristics

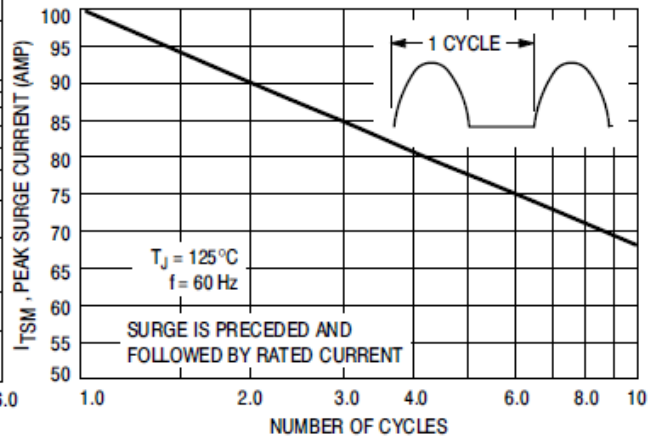

Figure 4. Maximum Non-Repetitive Surge Current

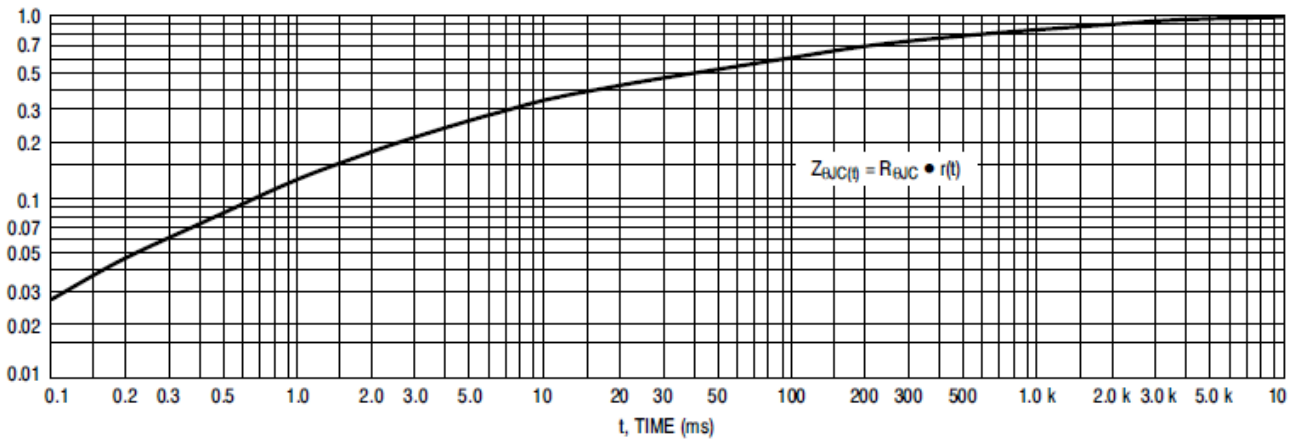

Figure 5. Thermal Response

DIGITRON SEMICONDUCTORS

MCR220-5, MCR220-7, MCR220-9

SILICON CONTROLLED RECTIFIER

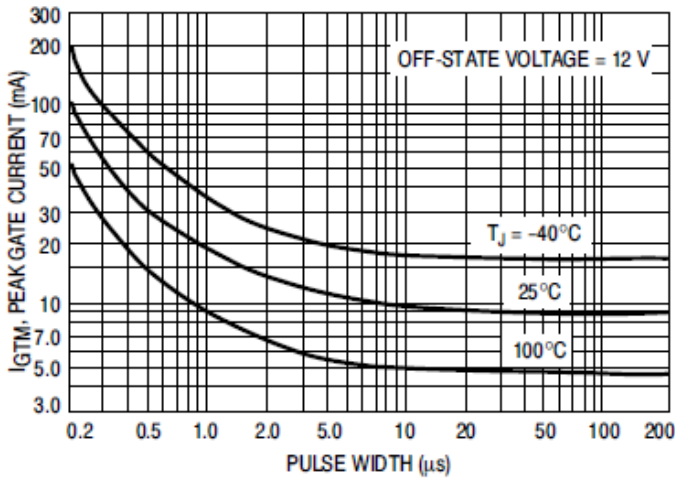

Figure 6. Typical Gate Trigger Current versus Pulse Width

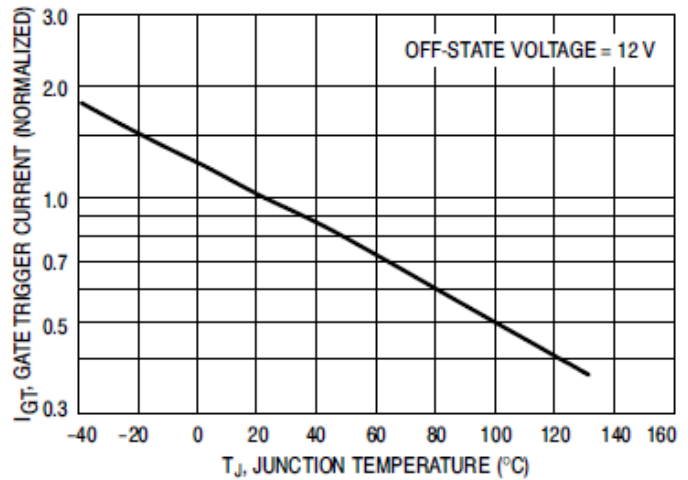

Figure 7. Typical Gate Trigger Current versus Temperature

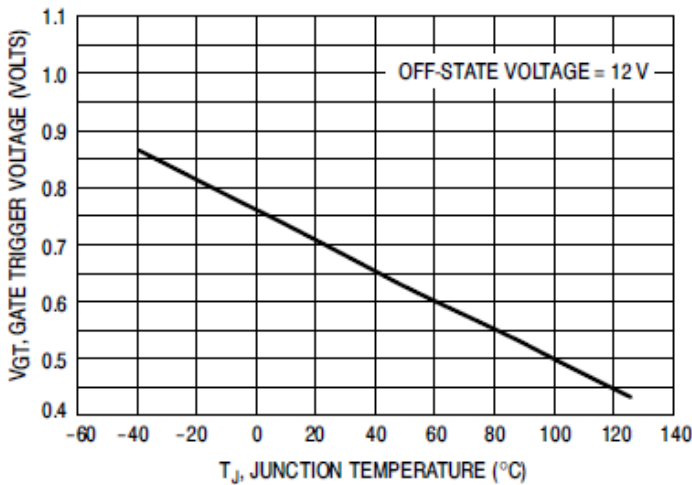

Figure 8. Typical Gate Trigger Voltage versus Temperature

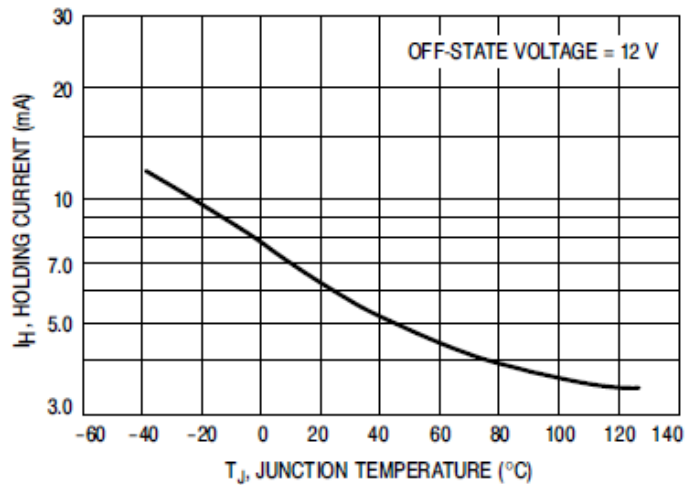

Figure 9. Typical Holding Current versus Temperature